

# BUSINESSPARK ALMERE

## PALMPOLSTRAAT

Verkoopbrochure

---

PROGRESSIO BV  
2023-0087B  
01-11-2023



agbvandijk.nl  
Maanderbuurtweg 39  
6718 XK Ede

**01****LIGGING PLANGEBIED**

Locatie van de betreffende kavel.

**02****PLATTEGRONDEN**

Plattegronden van de nieuwe situatie.

**03****GEVELS**

Gevelaanzichten van de panden.

**04****DOORSNEDE**

Doorsnede van de nieuwbouw.

**05****BEDRIJFSUNITS**

Plattegronden en gevelaanzichten per type unit.

**06****UNITS**

Plattegronden en gevelaanzichten per type unit.

**07****GARAGEBOXEN**

Plattegronden en gevelaanzichten per type box.

**08****IMPRESSIES**

Diversie impressies van het project.



## LIGGING PLANGEBIED



▲ Beschrijving van bovenstaande afbeelding

In de huidige situatie bevindt zich op de kavel een groot tuincentrum, deze zal verwijderd worden t.b.v. de nieuwe ontwikkeling.

BusinessPark Almere wordt ontwikkeld en gerealiseerd op een absolute toplocatie op het bedrijventerrein Veluwsekant. De Veluwsekant is een zeer representatief bedrijventerrein en heeft door haar ligging een perfecte zichtlocatie vanaf de A6. Het bedrijventerrein bestaat uit meerdere gebieden en ligt aan de belangrijkste weg richting Almere Centrum, de Veluwedreef.

Vanaf de A6 is het bedrijventerrein binnen 1 minuut te bereiken. Almere Centrum is met het openbaar vervoer slechts 11 minuten verwijderd. Via de A6 bent u binnen 25 minuten in Amsterdam. Kortom, een goed bereikbare locatie voor uw onderneming!



PLATTEGRONDEN



BEGANE GROND | PEIL = 0

Bedrijfsunit Type A  
 NR. 1 t/m 12  
 Aantal: 12  
 Opp.: 88 M<sup>2</sup> (2-laags)

Bedrijfsunit Type B  
 NR. 13 t/m 24  
 Aantal: 12  
 Opp.: 107 M<sup>2</sup> (2-laags)

Bedrijfsunit Type C  
 NR. 25 t/m 36  
 Aantal: 12  
 Opp.: 160 M<sup>2</sup> (2-laags)

Unit Type D  
 NR. 37 t/m 50  
 Aantal: 14  
 Opp.: 33 M<sup>2</sup>

Unit Type E  
 NR. 51 t/m 62  
 Aantal: 12  
 Opp.: 44 M<sup>2</sup>

Unit Type F  
 NR. 63 t/m 74  
 Aantal: 12  
 Opp.: 52 M<sup>2</sup>

Unit Type G  
 NR. 75 t/m 89  
 Aantal: 15  
 Opp.: 57 M<sup>2</sup>

PLATTEGRONDEN

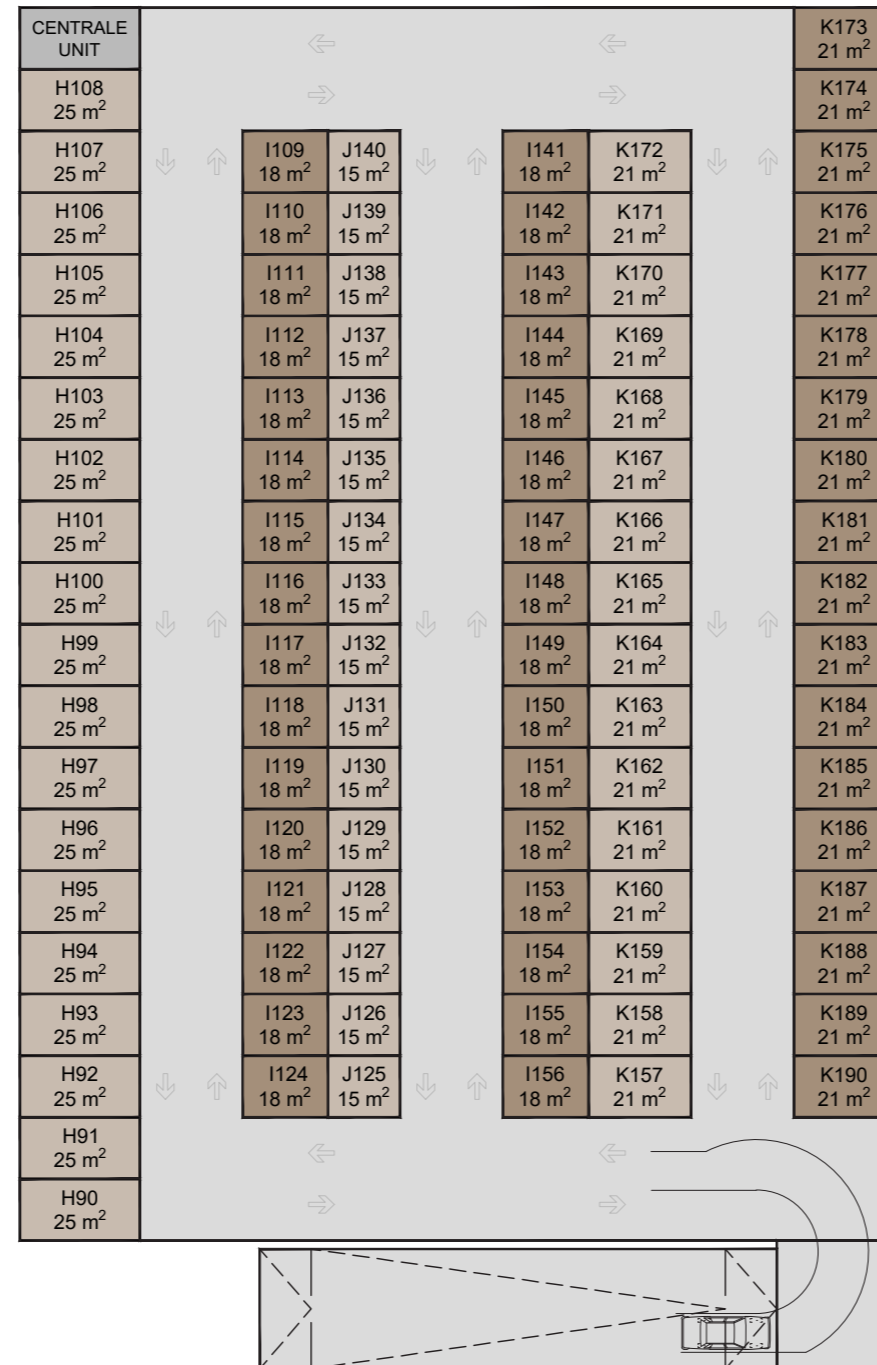

Opslagbox Type H  
NR. 90 t/m 108  
Aantal: 19  
Opp.: 25 M<sup>2</sup>

Opslagbox Type I  
NR. 109 t/m 124, 141 t/m 156  
Aantal: 32  
Opp.: 18 M<sup>2</sup>

Opslagbox Type J  
NR. 125 t/m 140  
Aantal: 16  
Opp.: 15 M<sup>2</sup>

Opslagbox Type K  
NR. 157 t/m 190  
Aantal: 34  
Opp.: 21 M<sup>2</sup>

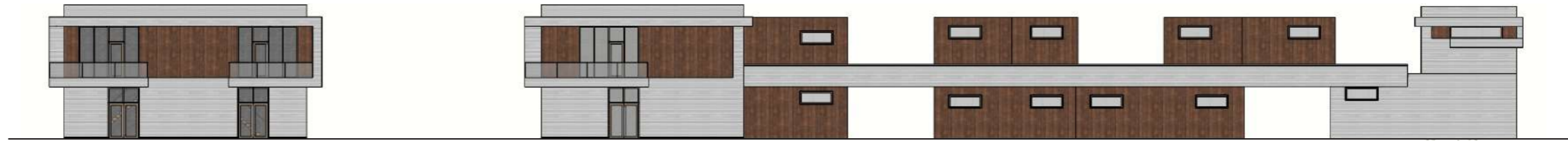

**VOORGEVEL**



**LINKER ZIJGEVEL**



**AANZICHT UNITS & GARAGEBOXEN**

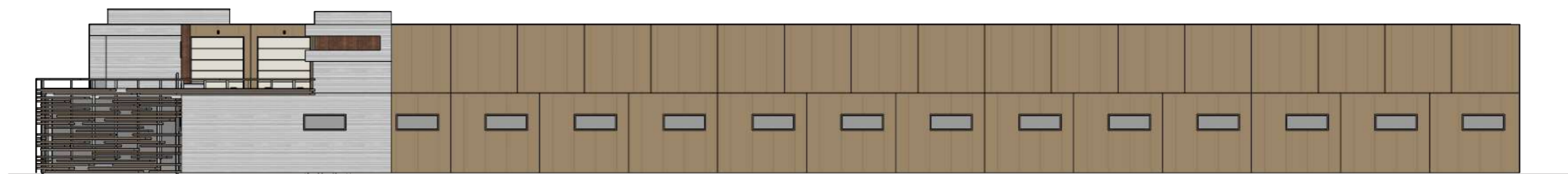

**RECHTER ZIJGEVEL**

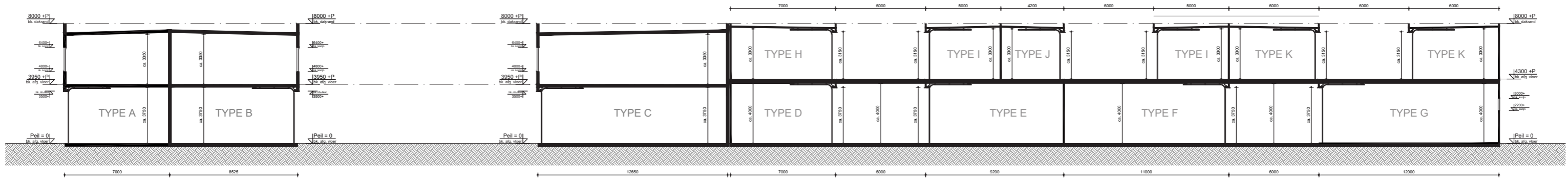

**PRINCIPEDOORSNEDE**

KOPUNIT TYPE A

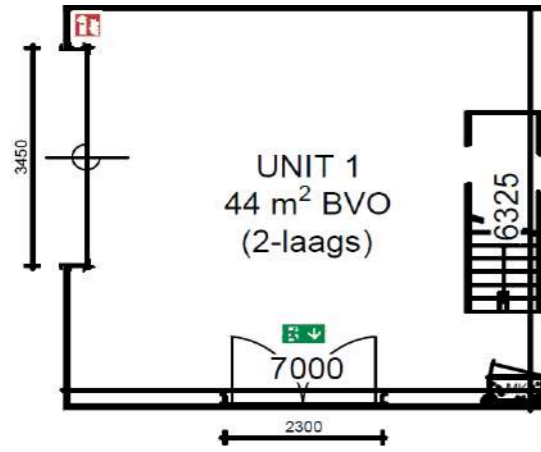

BEGANEGROND

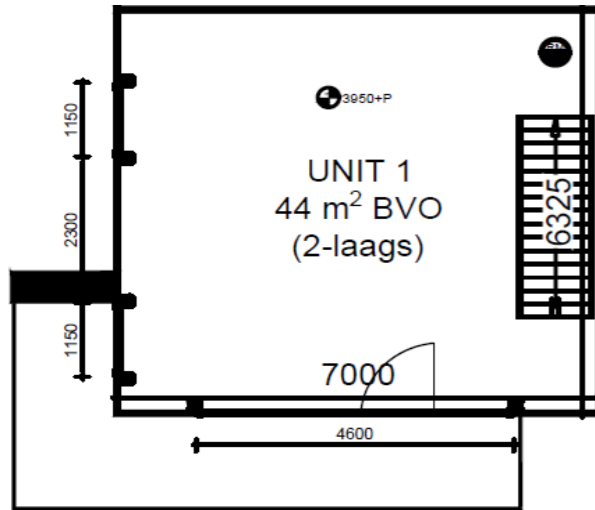

VERDIEPING

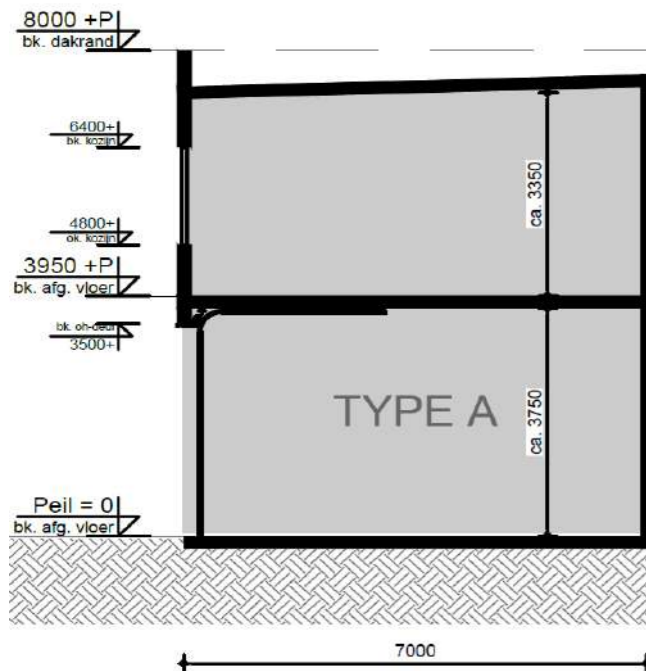

VOORGEVEL



ZUGEVEL



UNIT TYPE A

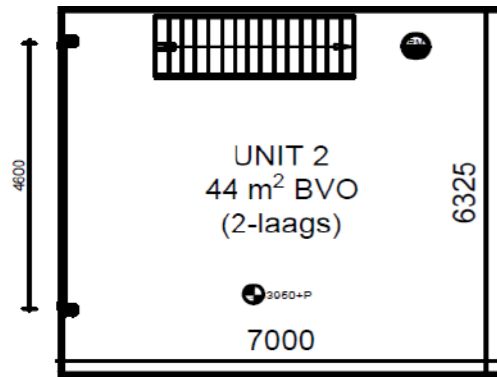

BEGANEGROND

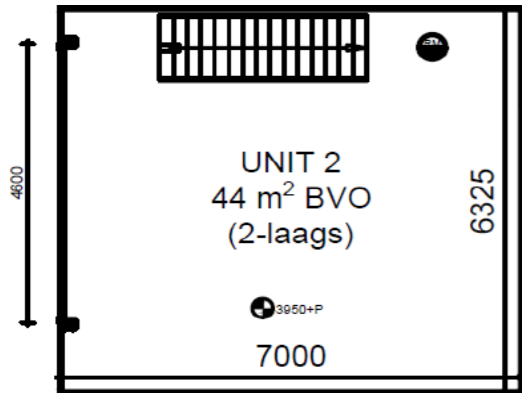

VERDIEPING

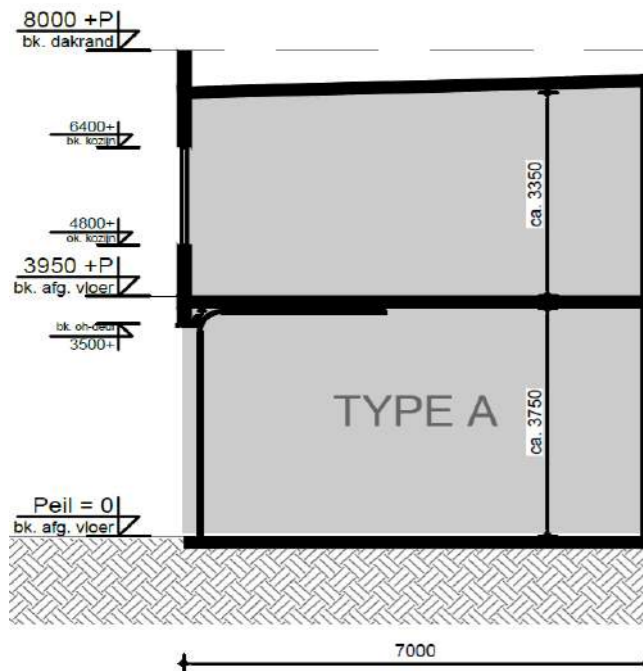

DOORSNEDE

UNIT TYPE A

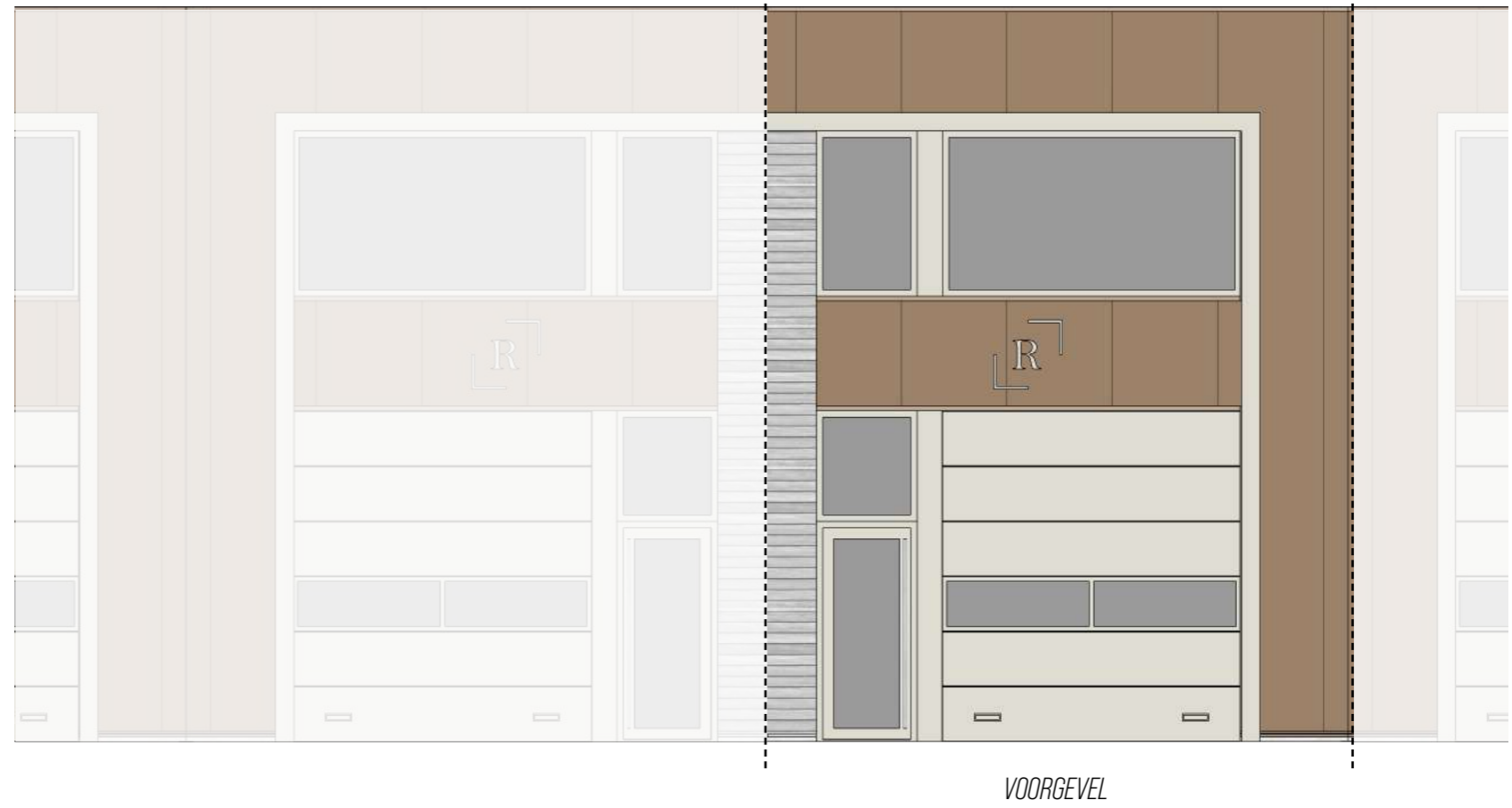

BEDRIJFSUNITS

KOPUNIT TYPE B

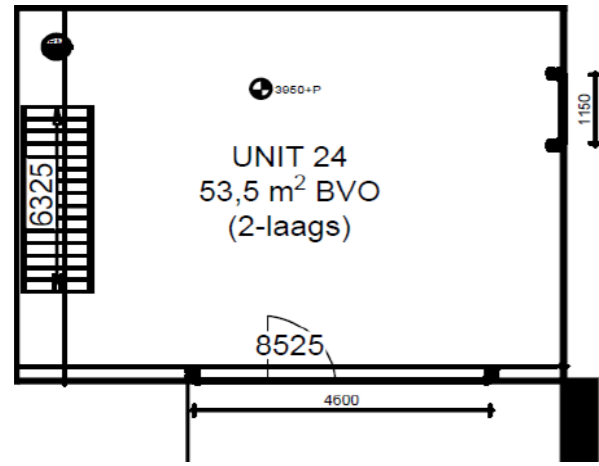

BEGANEGROND

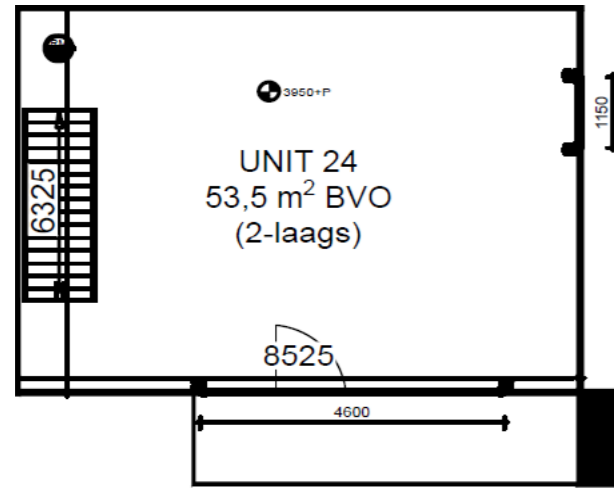

VERDIEPING

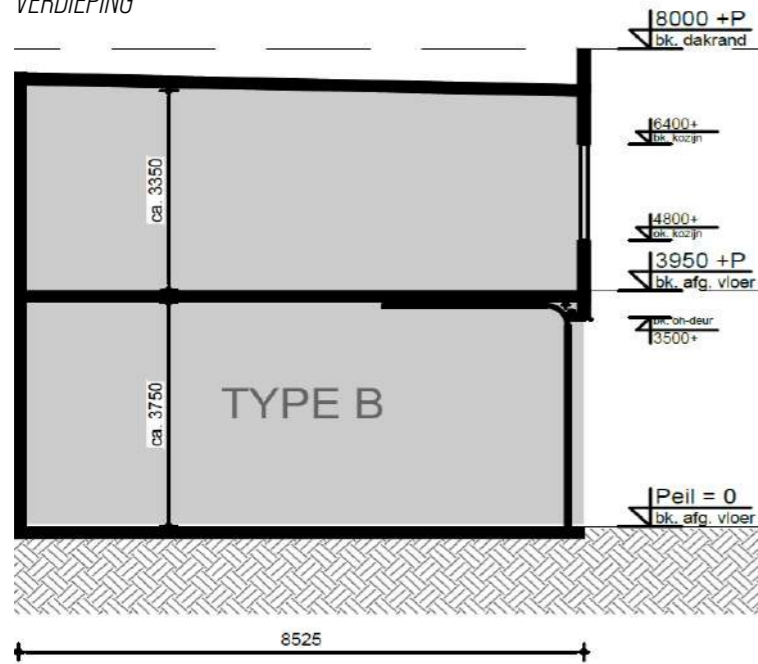

DOORSNEDE



VOORGEVEL



ZIJGEVEL



UNIT TYPE B

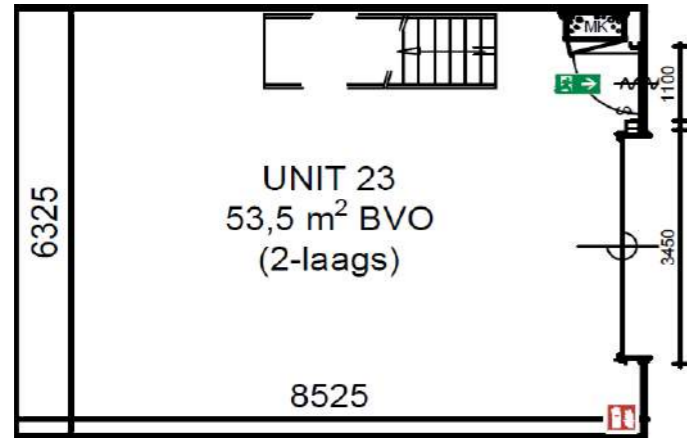

BEGANEGROUND

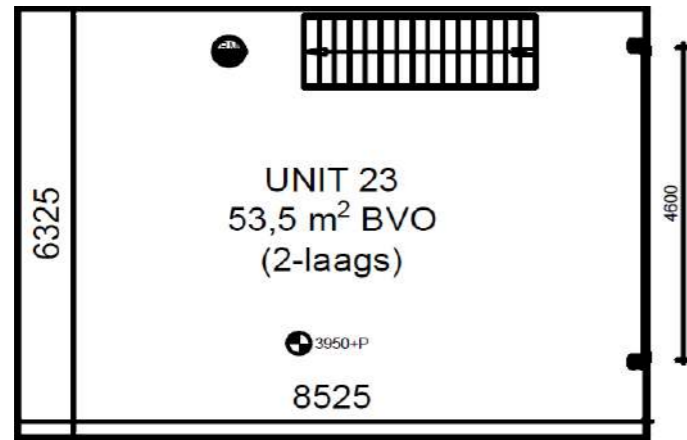

VERDIEPING

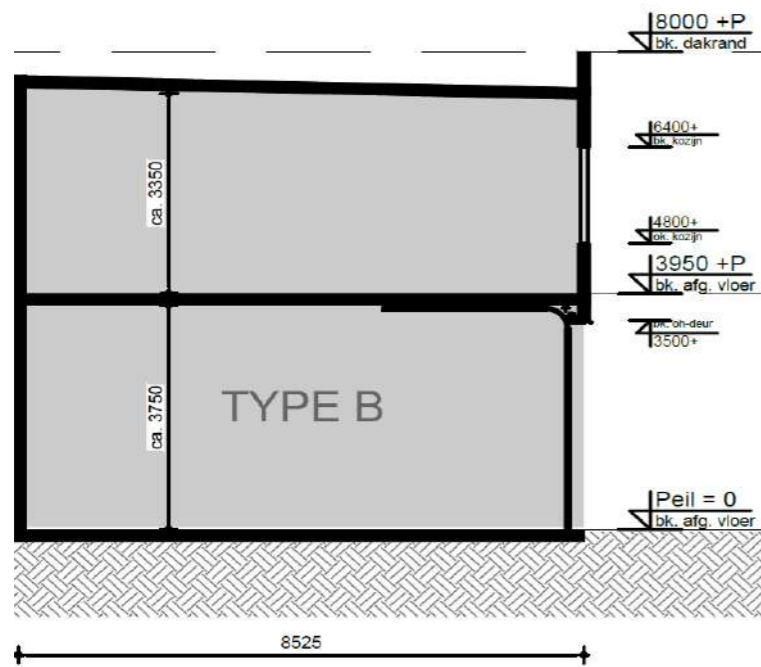

DOORSNEDE

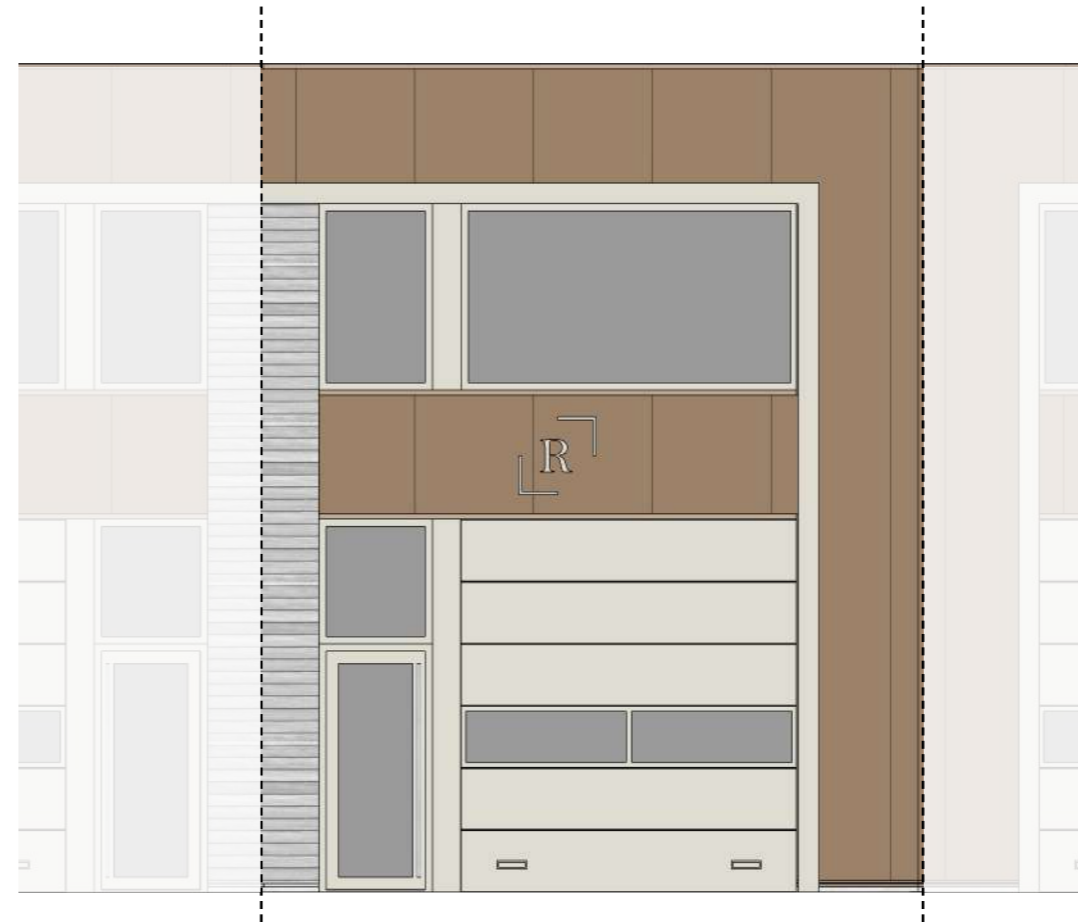

VOORGEVEL

KOPUNIT TYPE C

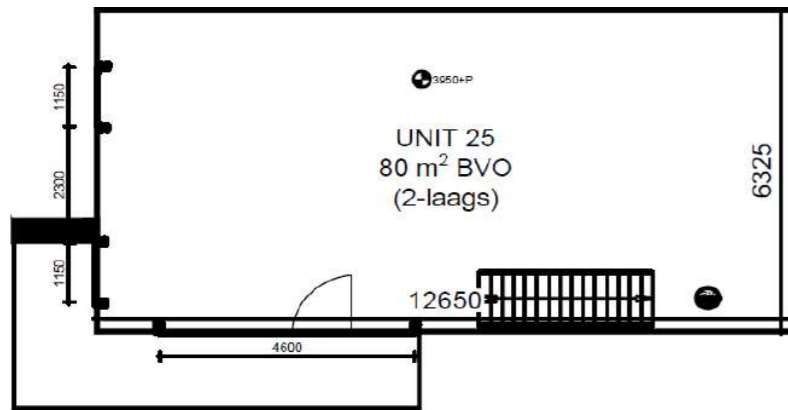

BEGANEGROND

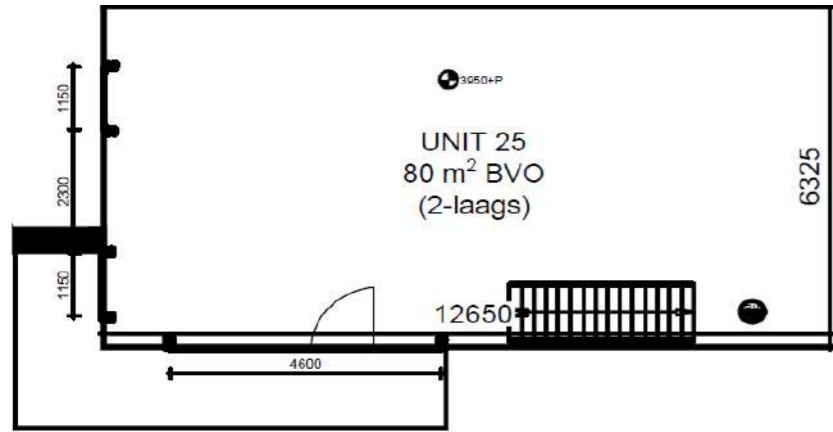

VERDIEPING

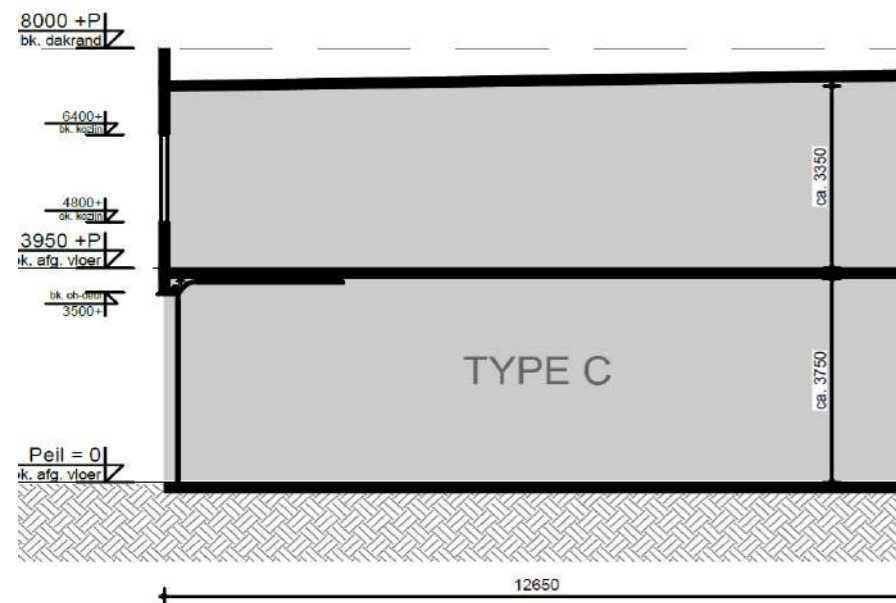

DOORSNEDE



VOORGEVEL



ZIJGEVEL



UNIT TYPE C

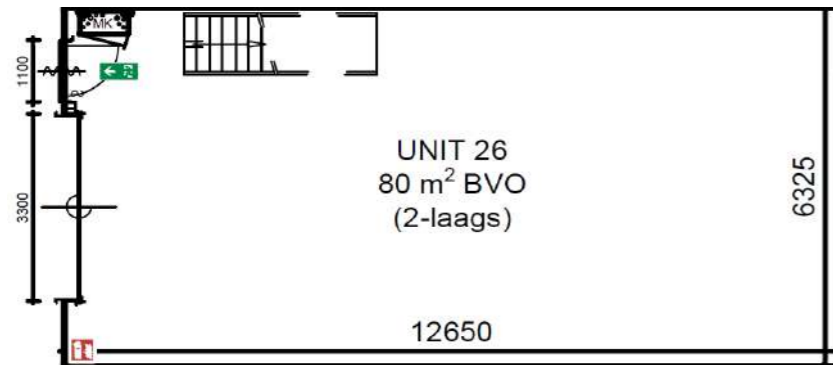

BEGANEGROND

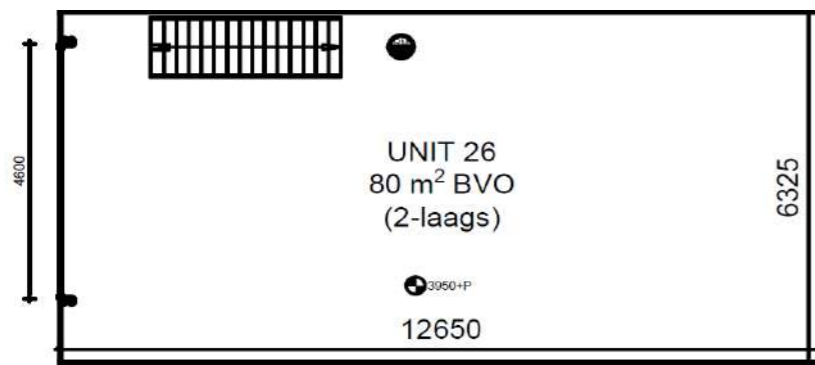

VERDIEPING

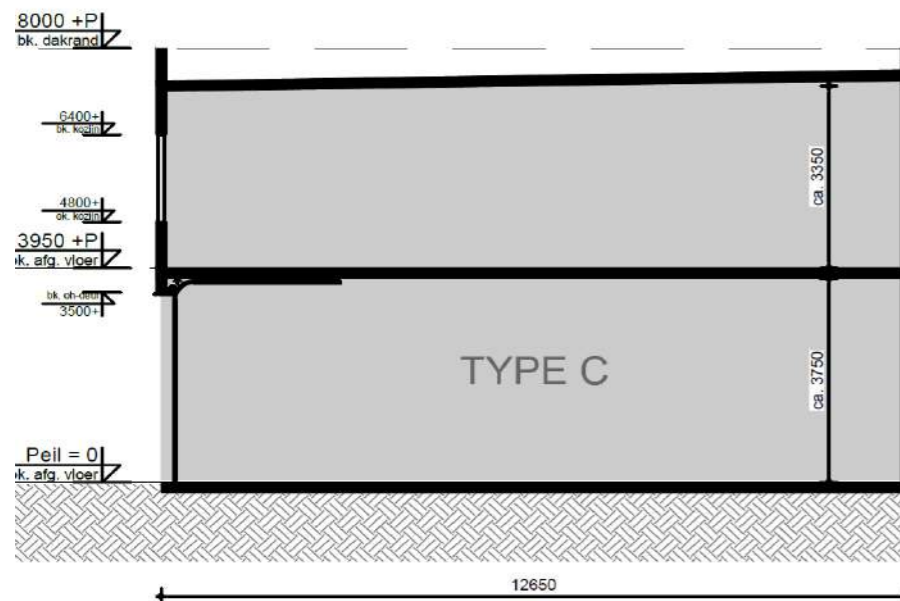

DOORSNEDE



**UNIT TYPE D**

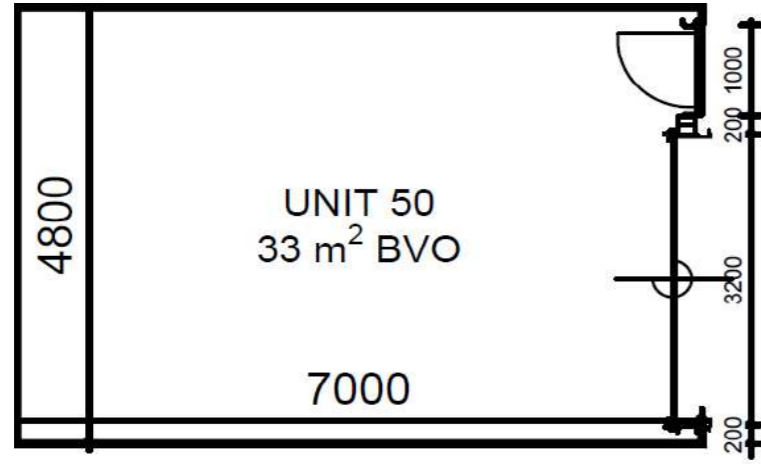

BEGANEGROND



VOORGEVEL

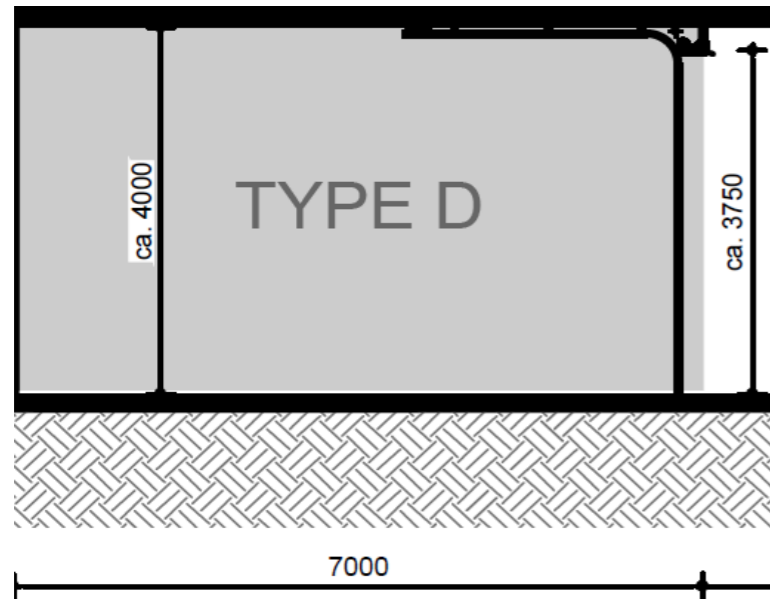

DOORSNEDE



ZIJGEVEL KOPUNIT



BOX TYPE E

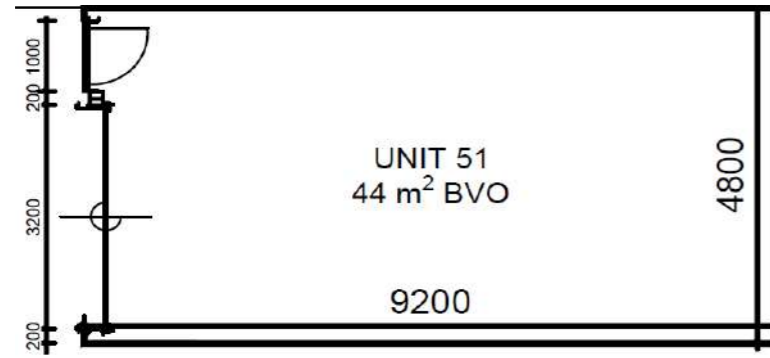

BEGANEGROND



VOORGEVEL

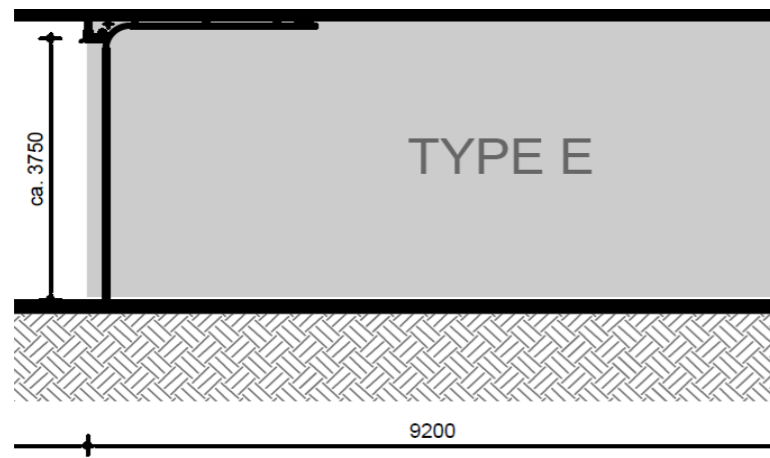

DOORSNEDE

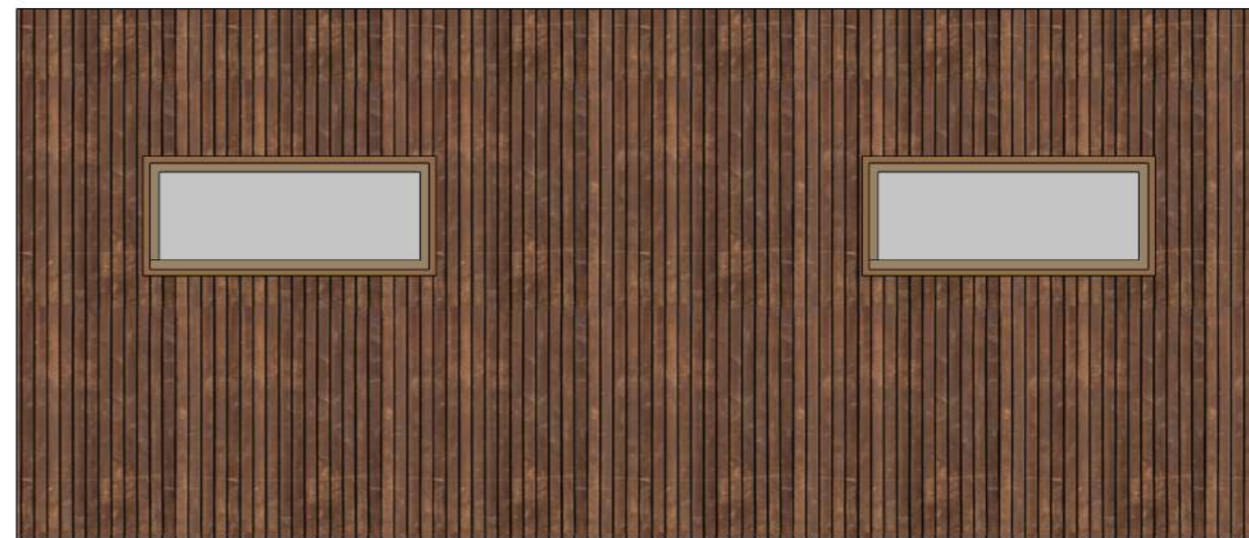

ZIJGEVEL KOPUNIT

BOX TYPE F

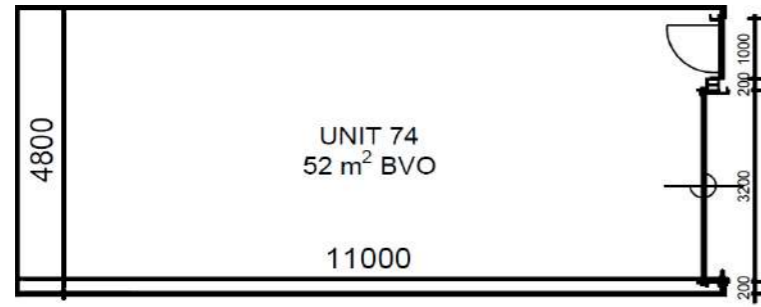

BEGANEGROND



VOORGEVEL

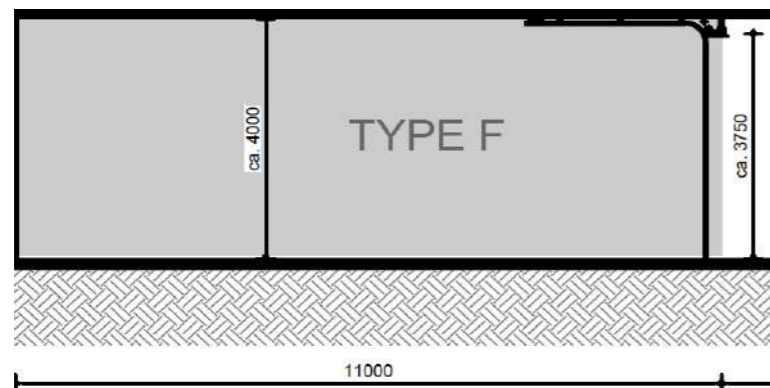

DOORSNEDE



ZIJGEVEL KOPUNIT

BOX TYPE G

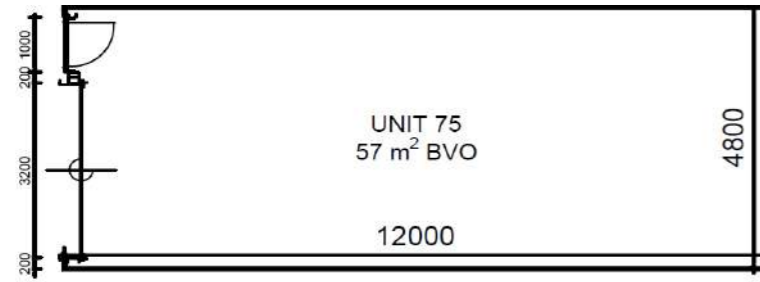

BEGANEGROND



VOORGEVEL

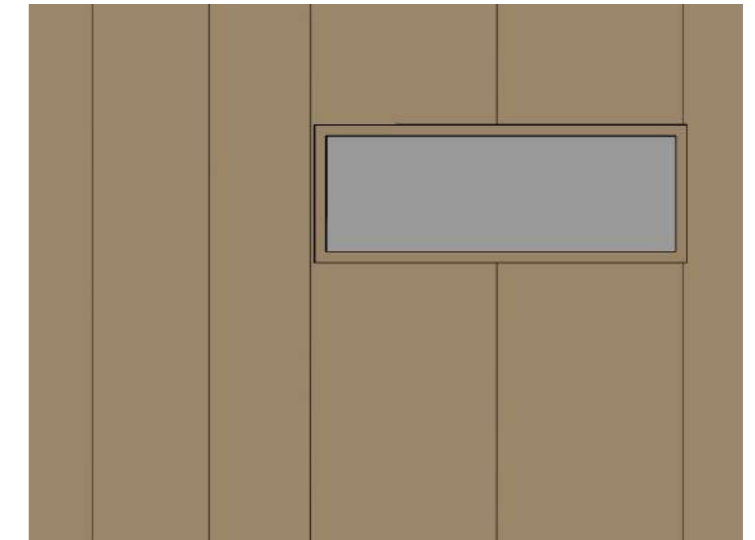

ACHTERGEVEL

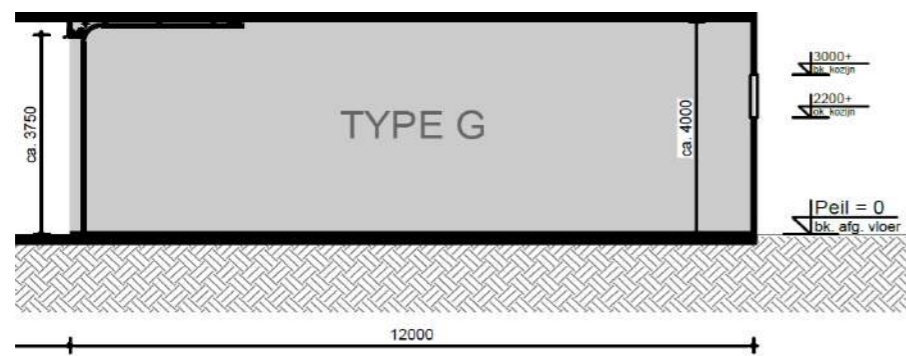

DOORSNEDE

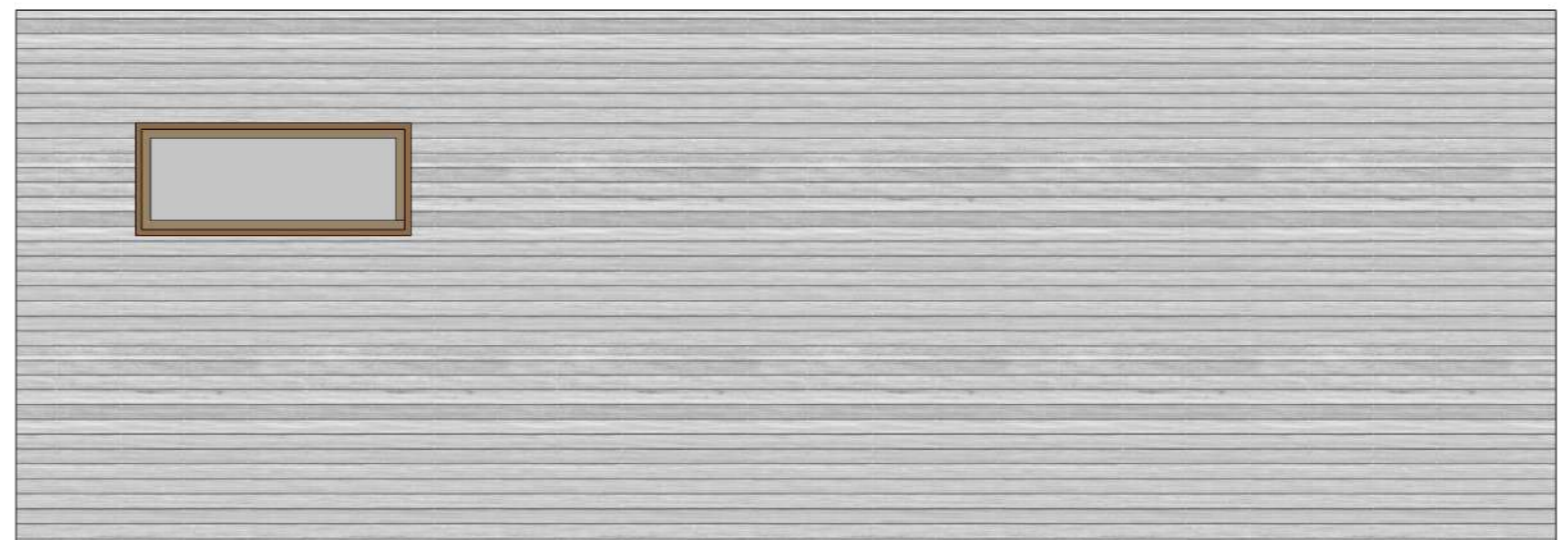

ZIJGEVEL KOPUNIT



BOX TYPE H

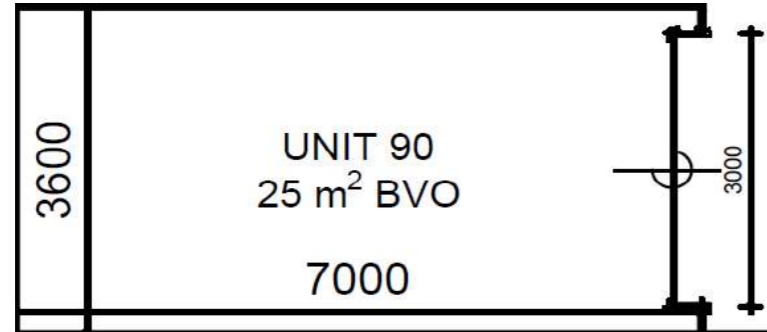

PLATTEGROND



VOORGEVEL

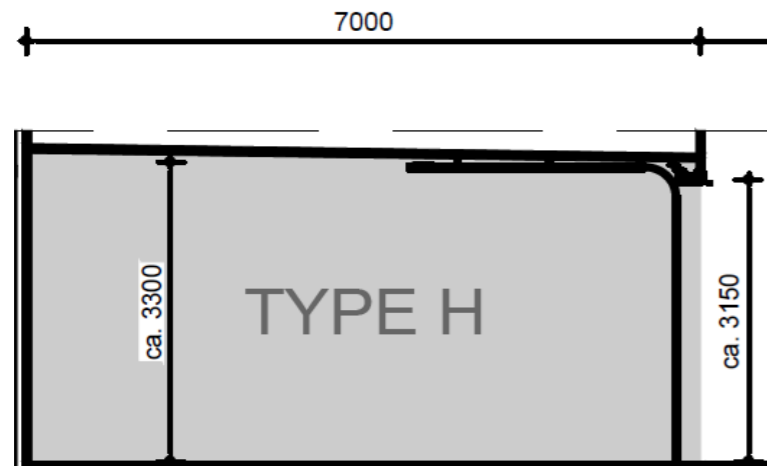

DOORSNEDE

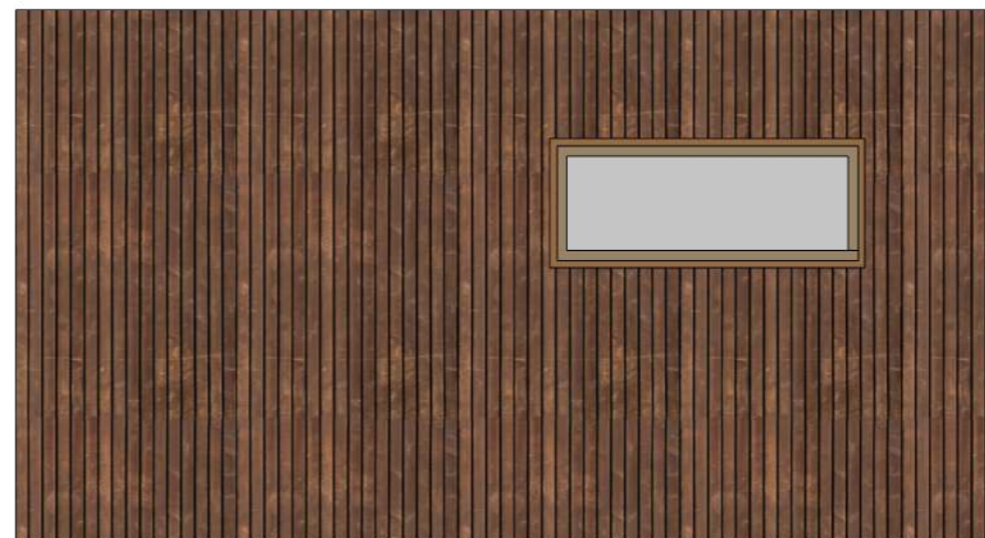

ZIJGEVEL KOPUNIT

BOX TYPE I

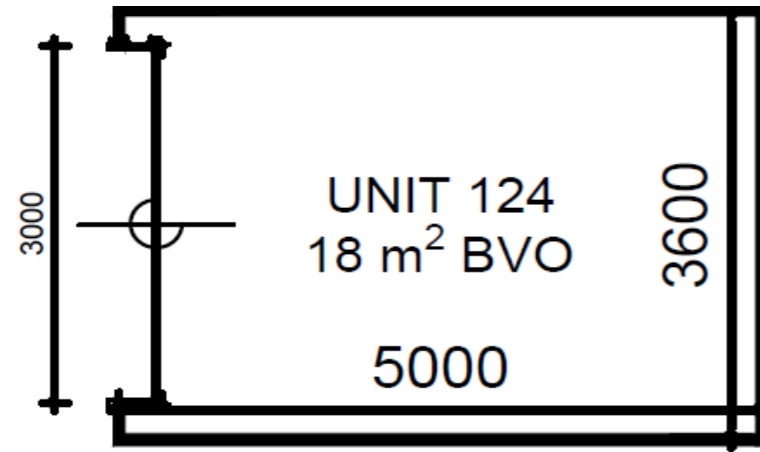

PLATTEGROND



VOORGEVEL

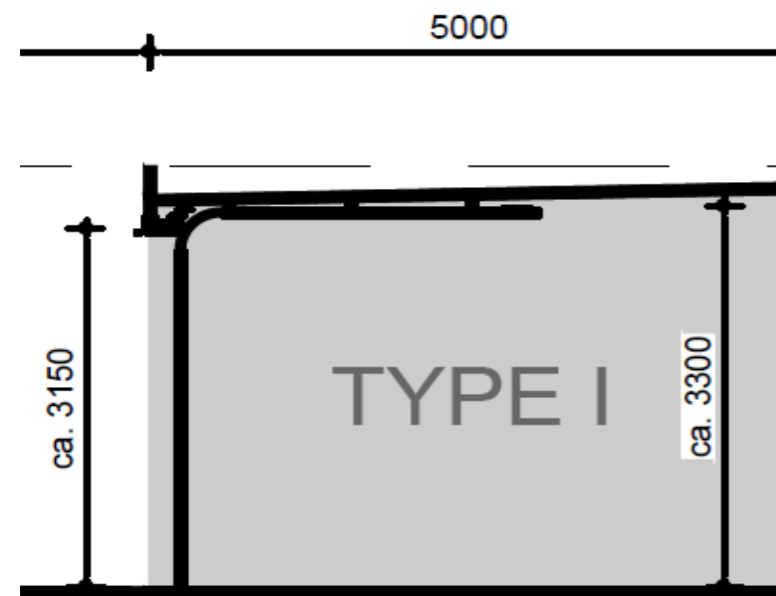

DOORSNEDE

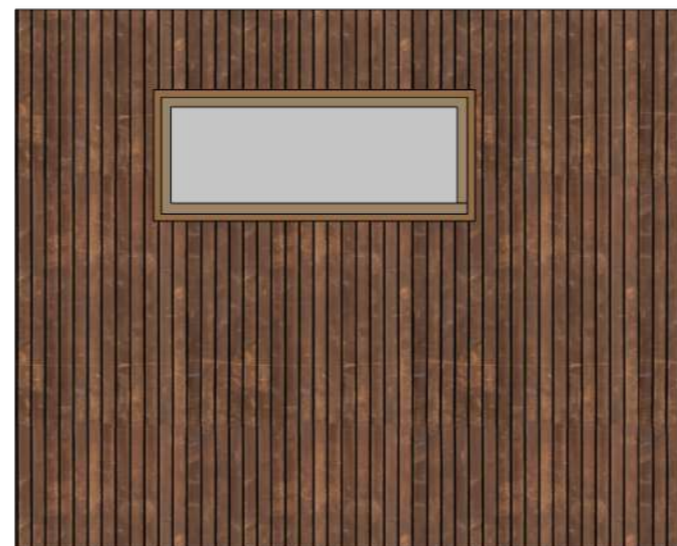

ZIJGEVEL KOPUNIT

BOX TYPE J

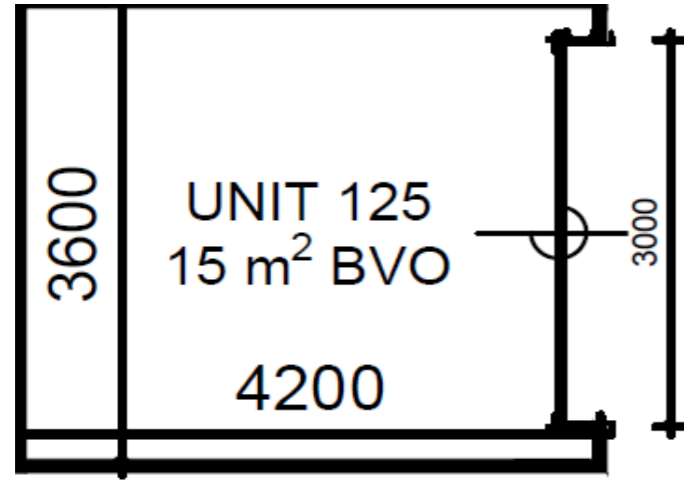

PLATTEGROND

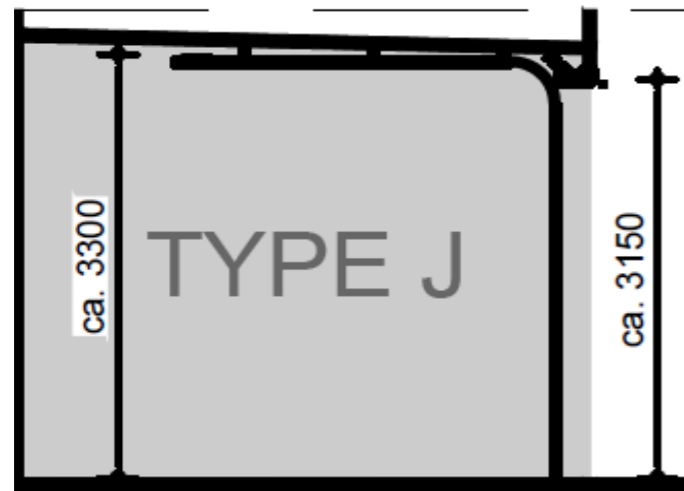
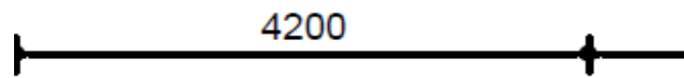

DOORSNEDE



VOORGEVEL



ZIJGEVEL KOPUNIT



BOX TYPE K1

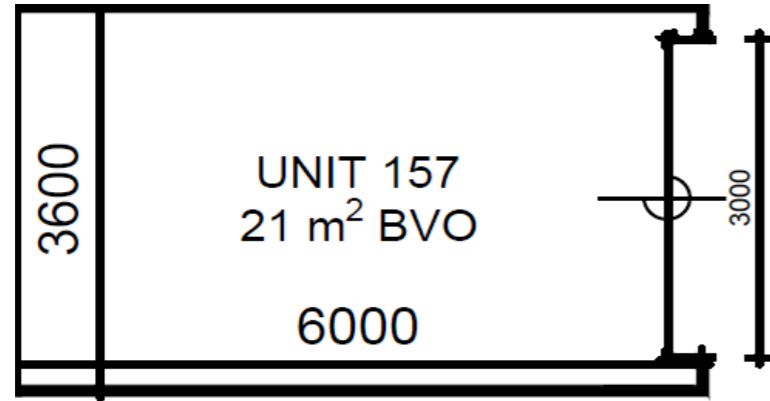

PLATTEGROND



VOORGEVEL

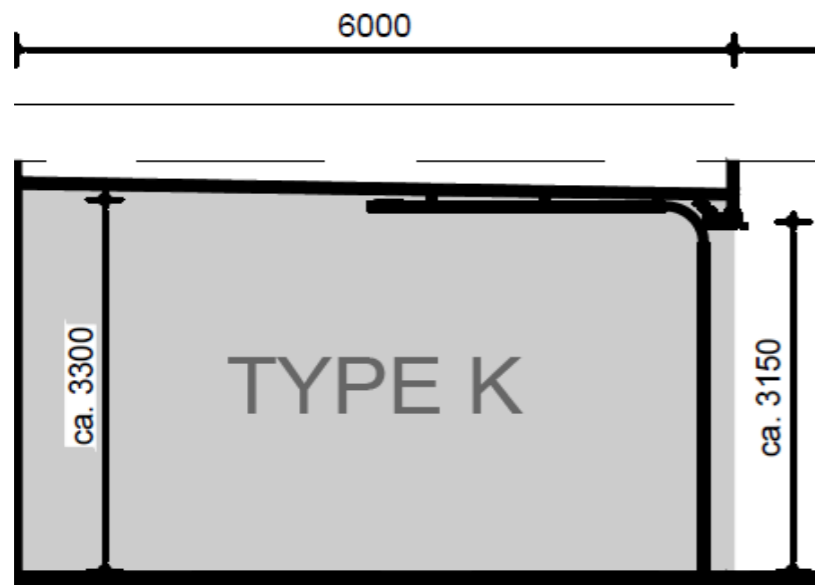

DOORSNEDE

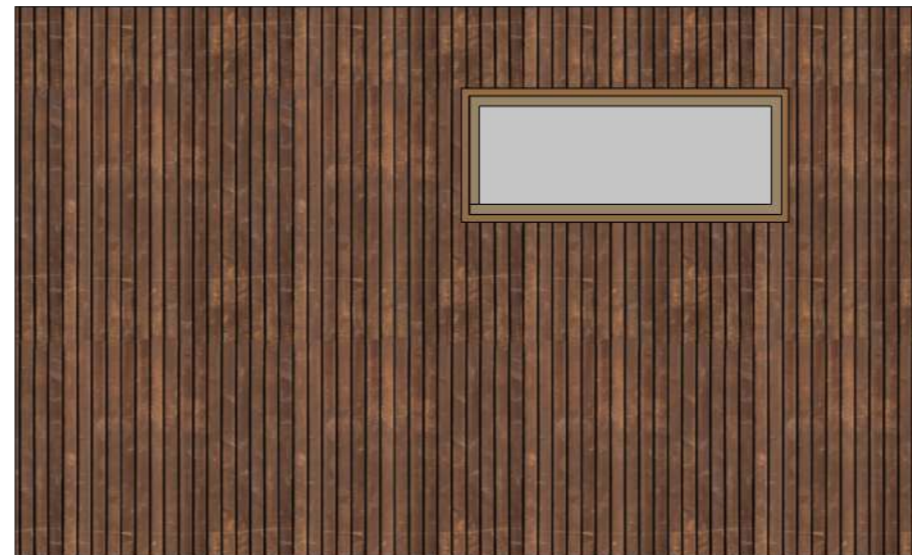

ZIJGEVEL KOPUNIT

BOX TYPE K2

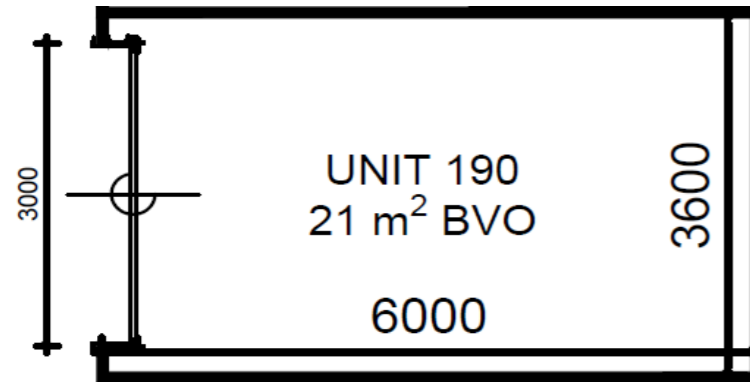

PLATTEGROND

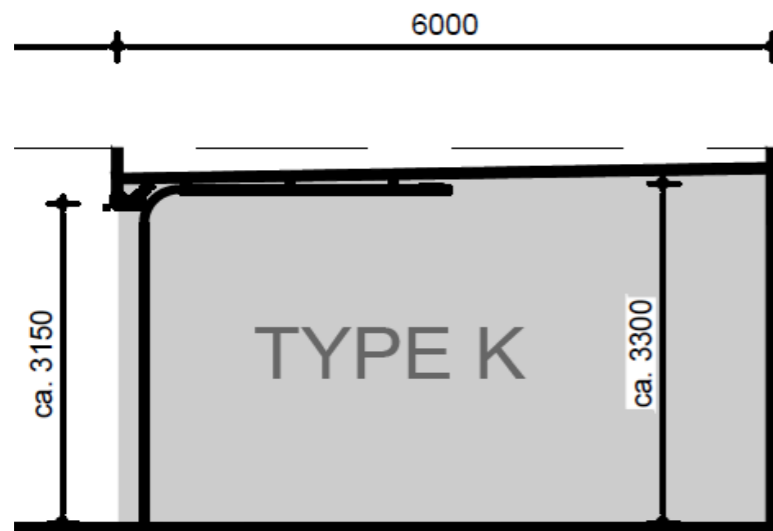

DOORSNEDE

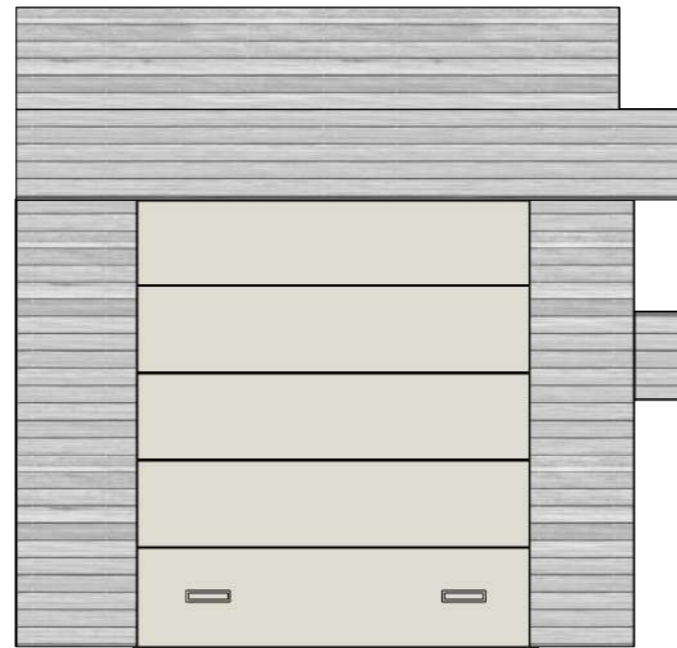

VOORGEVEL



ZIJGEVEL KOPUNIT























































VERDIEPING KOPUNIT C





### BEGANE GROND KOPUNIT C





**VERDIEPING UNIT TYPE A,B,C**





BEGANE GROND UNIT TYPE A,B,C





UNIT TYPE G





OPSLAGBOX TYPE I





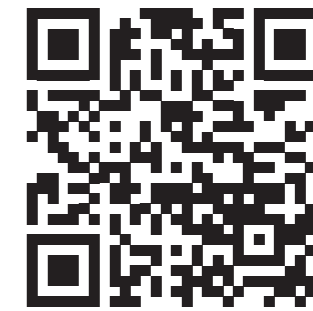

Scan mij!

Integraal denken is onze leidraad - de verbinding van verschillende disciplines in het ontwikkelproces. Daarom hebben wij alle belangrijke disciplines voor het ontwerp in huis; van in- en exterieur tot kostenbeheersing en exploitatie. Wij geloven dat de basis voor de perfecte realisering van een project de integrale samenwerking met zowel de eindgebruikers als ontwikkelaars met goed onderling overleg is.

Voor de toekomst zien wij volop kansen voor het bestaande vastgoed, nieuwe beschikbare locaties en de vraag vanuit de markt.

*AGB VAN DIJK*

